

LIGHTING LED Cure

MCC4000A

- Special designed component
- Optimized UV LED Controller
- Up to 4-Head UV-LED Connected



Feature

- Compact designed controller
- High power and high reliability
- Low power consumption
- Low price

Components



[LED controller MCC4000A]



[Extension cable/optional EC-□m]



[UV-LED Cure Head/UH-12S-150-□]

LED controller MCC4000A

Model	MCC4000A
Power input	DC 12V
Current consumption	DC12V / 2.5A
Power consumption	30W
Dimensions	175mm(W) x 110mm(L) x 50mm(H)
Weight	620g (Without Adaptor)
Operating temperature	+5°C ~ +35°C (Non-condensing)
Operating humidity	20% ~ 80% (Non-condensing)
Storage temperature range	-10°C ~ +50°C (Non-condensing)
Storage humidity range	Under 80% (Non-condensing)
Place of usage	Indoor
Connection port of LED Head unit	1 to 4 (Head Unit is operated separately in standard, If needed, 2 PORT or 4 PORT control can be achieved via UV LED MODE settings)
Irradiation Control	<ul style="list-style-type: none"> • MANUAL Mode irradiation • TIME Mode irradiation • STEP Mode Irradiation (Total 10 steps) <p>(Each step can be set between 0 to 99.9% of light intensity and 0 to 99.9 seconds of time setting)</p>
Light Intensity Adjustment	0% to 99.9%
Setting / Control	Operation with the button on the Controller front panel and external signal / Setting and operation by Software
Display	FND 4 digit (Current status) / 3 Status LED indicator for each port (RUN, STANDBY, ERROR)
External control	<ul style="list-style-type: none"> • Output : RUN / ERROR signal • Input : Trigger / Emergency signal
Control method	Constant current PWM/ Lock & STD Mode/ Trigger type control
Error	Basic EMG Stop Function, Circuit of LED is opened



[Front panel]

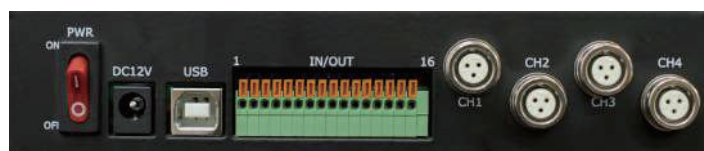

[Rear panel]

UV LED Head Specification



LED Head
(included cable 1.5m) 1 to 4

Item No.	UH-125-150-□
Lens	6LP, 8LP, 10LP, 3-15Lp
Light intensity distribution	Refer to the data on the graph
Head dimension	Head external diameter Ø12 / Length 53.5 to 56.8 mm (It is different according to the lens type)
Cable length	1.5 m
Weight	Approx. 70 g

- AGING TEST (Intensity / Temperature)

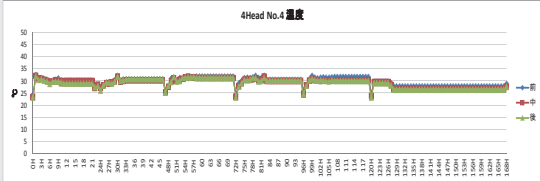
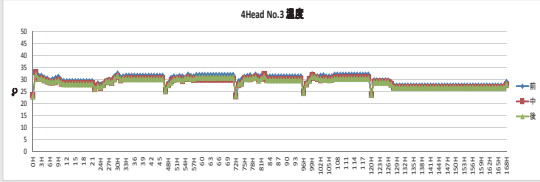
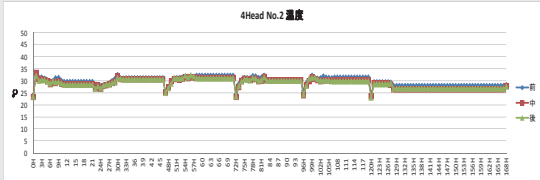
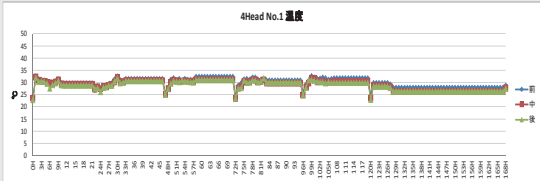
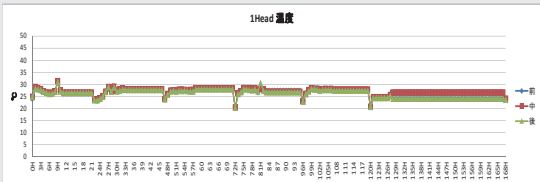
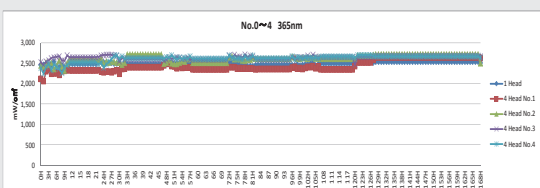

- Intensity / Special designed for FC-400 controller

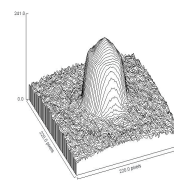
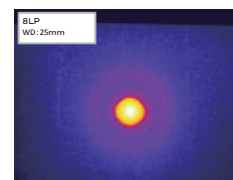
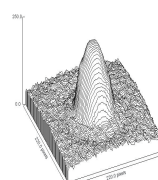
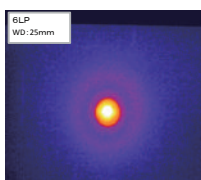
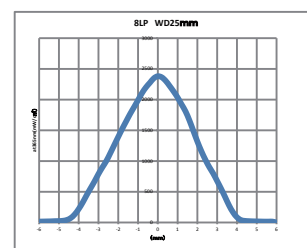
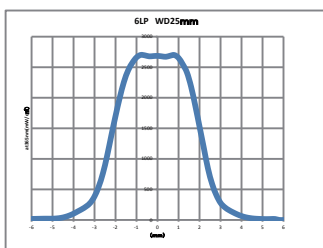

- Intensity / STANDARD Type

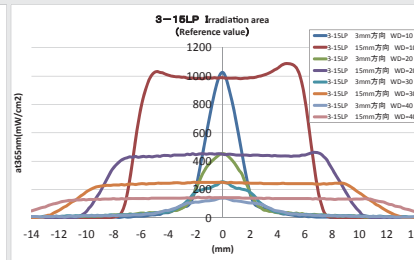
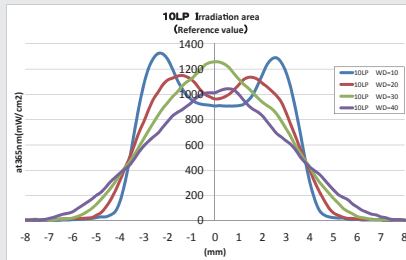
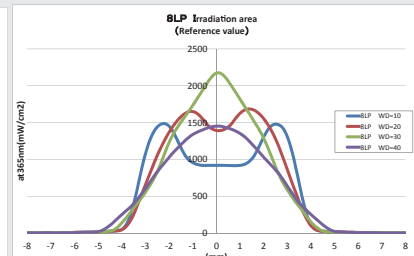
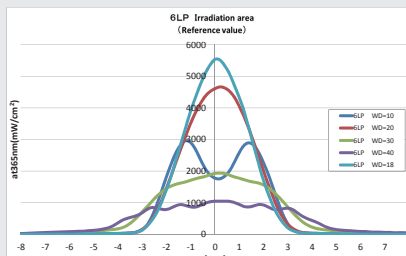

- Connector Specification



PRC05-P3M



PRC05-3F

PRC05-3M

- Lens shape

It can be developed by customer's requirement.



[Special lens]



[Standard lens]

Controller MCC4000A

(단위:mm)

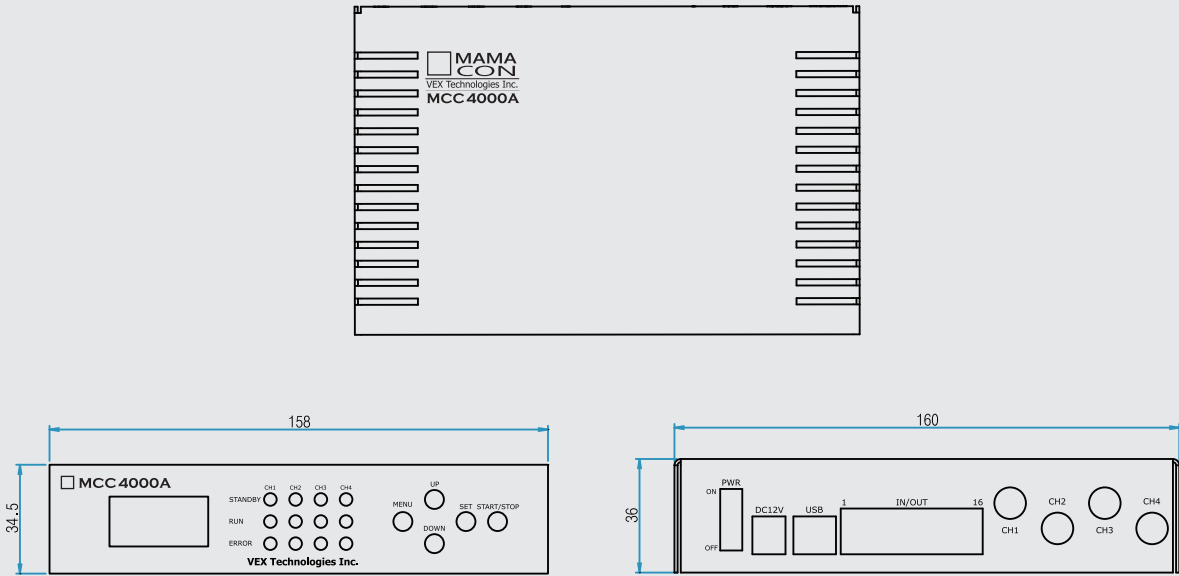

Special designed for HVS

STANDARD 1

STANDARD 2

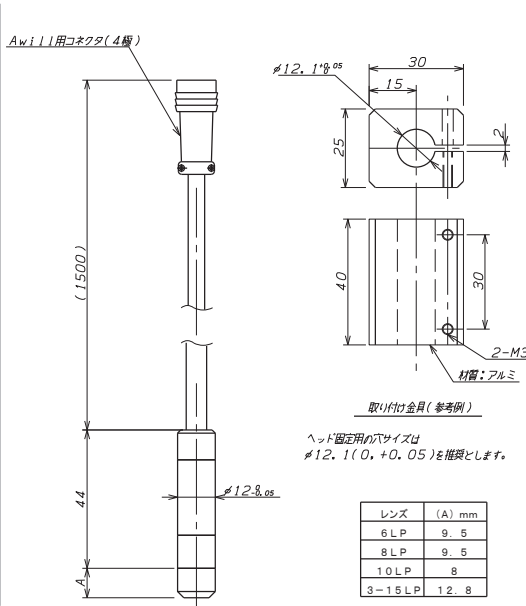
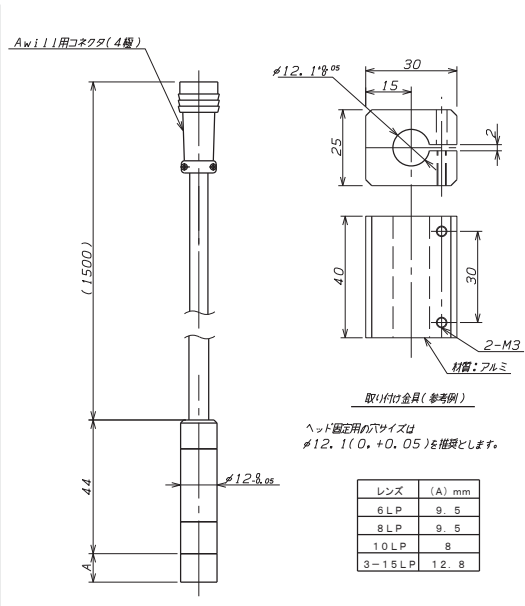
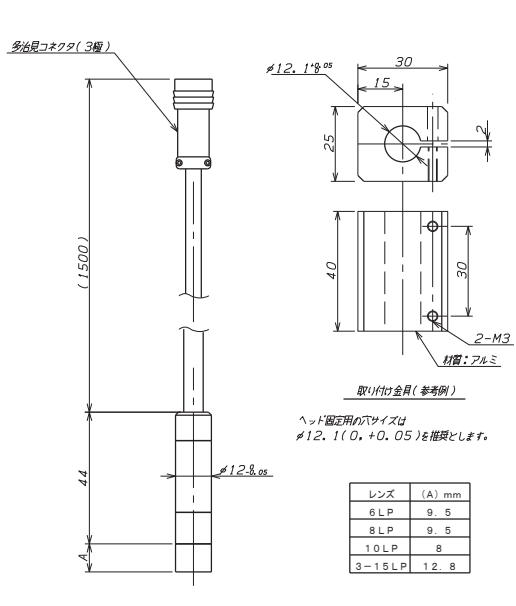

* Above data can be changed without prior notice [May.2015]